

RocknRoller Multi-Cart: Owner's Manual

Congratulations on your purchase of RocknRoller Multi-Cart, the most highly acclaimed and innovative carts or dollies ever. Although extremely easy to use, Multi-Cart's patented and ingenious design operates on a different principle than typical carts and dollies. To obtain maximum performance from your Multi-Cart, we recommend reading the owner's manual thoroughly. U.S. Patent # 5, 228,716; 5,476,282 & Pats. Pend.

LIMITED WARRANTY: Multi-Carts/RocknRollers carry a one year limited warranty against defective material or workmanship on basic frame and components. Casters and wheels carry a 60 day warranty against defects. As with any equipment, normal maintenance is required. Caution should be used when moving any load with Multi-Carts or any other dolly.

Cart Models

R2 (Micro)	R6 (Mini)	R8 (Mid)	R10 (Max)	R12 (All-Terrain)
RnR's smallest model expands from 26"-39" in length with 25"/20" (front/rear) foldable sides. 6"x1.50" rear wheels and 4"x1.0" front swivel casters w/o brakes. Load capacity: 350 lbs./24 cu. ft. Weight: 17 lbs.	Frame telescopes from 28"-42.5 in length with 24" foldable sides. 8"x2.50" pneumatic rear wheels and 4"x1.0" front swivel casters w/o brakes. Load capacity: 500 lbs./27 cu. ft. Weight: 25 lbs.	Identical to R10 except with 8"x2.50" pneumatic rear wheels resulting in 20% smaller storage footprint than R10. Load capacity: 500 lbs./32 cu. ft. Weight: 29 lbs.	Frame telescopes 34"-52" in length with 32" foldable sides to stack loads high. 10"x3.0" pneumatic rear wheels. 5"x1.25" front swivel casters, one w/brake. Load capacity: 500 lbs./32 cu. ft. Weight: 31 lbs.	Frame telescopes 34"-52" in length with 32" foldable sides to stack loads high. 10"x3.0" pneumatic rear wheels and 8"x2.50" pneumatic swivel casters w/o brakes. Load capacity: 500 lbs./32 cu. ft. Weight: 36 lbs.

Each RocknRoller Multi-Cart shipping box should contain a frame and the following parts:

Model R2	Models R6, R8, R10	Model R12
<ul style="list-style-type: none"> (2) 6"x1.50" (150mmx37mm) wheels (2) 4.0"x1.0" (100mmx25mm) stem casters (2) 1/2" flat washers (2) 1/2"-13 nylon lock nuts OR (nut + lock washer) (4) 1" (25mm) square plastic endplugs (12) 3/4" (20mm) square plastic endplugs 1/8" x 1" cotter pins (2) 16mm flat washer (1) Owner's Manual 	<ul style="list-style-type: none"> (2) 10"x3.0" (250mmx75mm) pneumatic wheels (R10) (2) 8"x2.5" (200mmx63mm) pneumatic wheels (R8/R6) (2) 5"x1.25" (125mmx32mm) stem casters (R10/R8) (2) 4.0"x1.0" (100mmx25mm) stem casters (R6) (2) 1/2"-13 lock nuts OR (nut + lock washer) (2) 1/2" flat washers (5) 1" (25mm) square plastic endplugs (13) 3/4" (20mm) square plastic endplugs (2) 1/8" x 1 1/4" cotter pins (2) 20mm flat washers (1) Owner's Manual 	<ul style="list-style-type: none"> (2) 10"x3.0" (250mmx75mm) pneumatic wheels (2) 8"x2.5" (200mmx63mm) pneumatic casters (5) 1" (25mm) square plastic endplugs (13) 3/4" (20mm) square plastic endplugs (4) 1/8" x 1 1/4" cotter pins (2) 20mm flat washers (1) Owner's Manual

Recommended Tools For Assembly

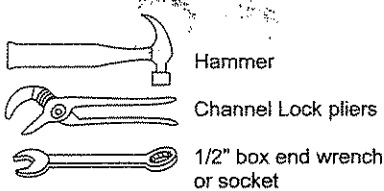

Assembly Instructions

CAUTION:

Be careful to not pinch or strike fingers during assembly. Be careful of metal burrs inside tubing.

1. Installing Rear Wheels

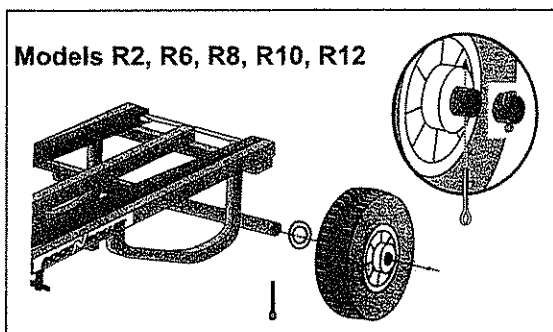

Gently slide wheel over axel as shown. Do not force wheels onto axel. It is recommended to lubricate axels with light grease before installing. Install cotter pins and bend ends outward. Pneumatic wheels: maintain tire pressure at 25 - 30 p.s.i. Make sure valve stem core is tightened using Schrader valve cap device. Check tire pressure periodically.

2. Installing Front Swivel Casters

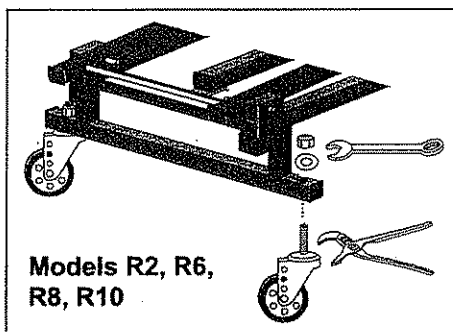

Attach front swivel casters as shown. While tightening lock nuts, grip bearing cap with channel lock pliers or pipe wrench to prevent threaded stem from turning. Tighten lock nuts firmly but not excessively tight.

Check lock nut tightness on casters stems periodically.

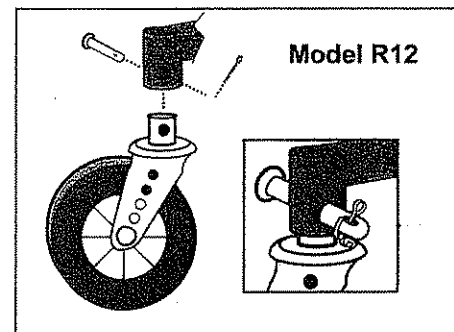

Carefully insert caster stem into receptor tube insuring that the caster stem holes line up with the receptor pin holes. The stem should fit very snugly in receptor tube. (If stem is difficult to insert into tube: Occasionally, a little excess paint or metal shavings get in the receptor tube. If so, take a fine grain sandpaper and ream it out a little. Then reinsert the caster stem.)

Operating Your RocknRoller Multi-Cart

Multi-Carts instantly transform into any of 8 different configurations: 1. short furniture dolly, 2. 2-wheel handtruck, 3. storage/transport, 4. short platform cart, 5. short hi-stacker, 6. long furniture dolly, 7. long hi-stacker, 8. long platform cart. When using Multi-Cart in extended 4-wheel dolly configuration, distribute load evenly over frame bed when possible, placing the heaviest items over the large rear wheels to make rolling easier. Over rough terrain it is recommended to push cart with the large wheels forward. **Caution: When loading equipment on a hill or incline, set brake. (Block wheels if load is very heavy). Caution should be used when moving any load with Multi-Carts or any other dolly.**

MULTI-CARTS TRANSFORM INTO 8 CONFIGURATIONS

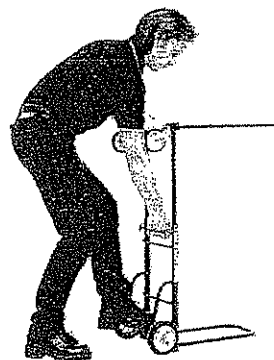
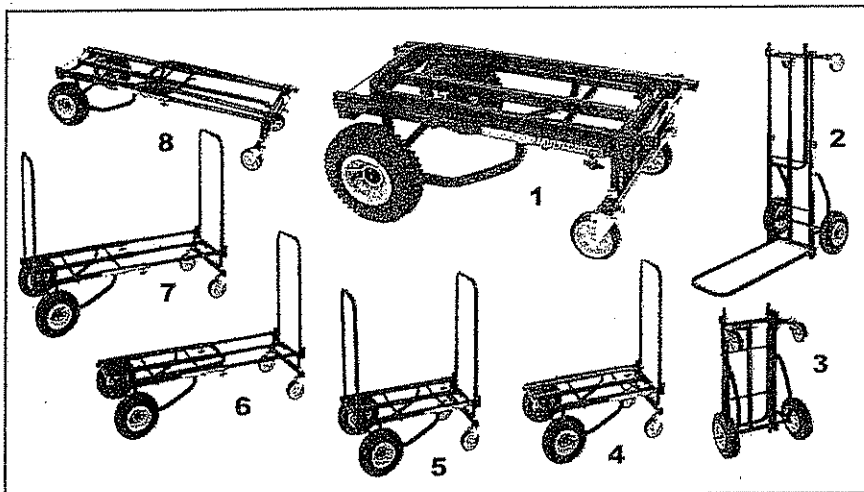

Extending Frame
Loosen wingbolts 1/4 turn. Step on rear axle and push in extension stop button. Pull up on frame as shown until stop button engages. Retighten wingbolts.

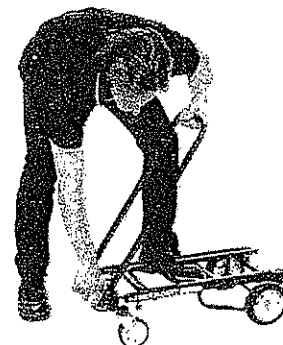

Raising Foldable Sides
Firmly press down on release cable while raising other end of foldable side as shown. Repeat with other side.

1. **SHORT FURNITURE DOLLY:** Place cart on all four wheels with sides folded down as shown.
2. **2-WHEEL HANDTRUCK:** Extend cart into 4-wheel hi-stacker configuration. Set on one end as shown, pull top release cable and lower top foldable side.
3. **STORAGE/TRANSPORT:** With sides upright, place cart on end, loosen wingbolts under frame 1/4 turn, push in extension stop button, and push down to compact cart to minimum length. Retighten wingbolts. Place cart on all 4 wheels. **FOLD HANDLES IN THIS ORDER:** 1st, push down release cable over large wheels with one hand and fold down side with the other hand. 2nd, fold side over front swivel casters in the same manner. Cart will not fold down correctly unless done in this order. Stand cart on end to store or place upside down to ride in vehicles or on airport conveyor belts.
4. **SHORT PLATFORM CART:** Firmly push down on release cable located over swivel casters with one hand while raising the foldable side with the other hand until side locks into place in upright position.
5. **SHORT HI-STACKER:** Raise both sides as previously described.
6. **LONG PLATFORM CART:** Take short hi-stacker configuration and set on 2 large wheels (upright). Loosen 2 wingbolts 1/4 turn and pull frame upward until button engages. Retighten wingbolts and set cart back on all 4 wheels.
7. **LONG HI-STACKER:** Raise folded handle of long platform cart.
8. **LONG PLATFORM CART:** From long hi-stacker configuration, fold down side over large wheels first, then fold down side over swivel casters.

RocknRoller Multi-Cart Distributors (United States)

United States (music industry)

Dana B. Goods
4054 Transport Street, Ventura, CA 93003
Tel: 805-856-1700 Fax: 805-644-6332
E-mail: info@danabgoods.com
Web: www.rocknrollercart.com

United States (industrial packaging)

Penn-Elcom, Inc.
12691 Monarch Street, Garden Grove, CA 92841
Tel: 714-230-6200 Fax: 714-230-6222
Email: california@penn-elcom.com
Web: www.penn-fabrication.com

United States (electrical industry)

Platt Cases
4051 West 51st Street, Chicago, IL 60632
Tel: (800) 222-1555 Fax: (773) 838-2010
Email: info@plattcases.com
Web: www.plattcases.com

United States (photo industry)

Multi-Cart
8 Westchester Plaza, Eimsford, NY 10523
Tel: 914-347-3300 Fax: 914-347-3309
E-mail: info@multicart.com
Web: www.multicart.com

Penn-Elcom, Inc.

9772 Whitorn Drive, Houston, TX 77095
Tel: 281-855-9772 Fax: 281-855-4856
Email: texas@penn-elcom.com
Web: www.penn-fabrication.com

United States (office products industry)

Advantus Corp.
12276 San Jose Blvd., Bldg. 618, Jacksonville, FL 32223
Tel: 904-482-0091 Fax: 904-482-0099
Email: info@advantus.com
Web: www.advantus.com

RocknRoller Multi-Cart Distributors (International)

See URL: www.rocknrollercart.com/intl_distr.htm

RocknRoller Multi-Cart Maintenance Tips

RocknRoller Multi-Carts require very little maintenance but they do require some. This is especially important if you are using your cart for professional purposes.

TIRES

1. Tip: Keep your tires inflated to proper pressure (30 p.s.i.). All pneumatic wheels (i.e. carts, trucks, bicycles, wheelbarrows, etc.) need to have the tires inflated periodically. Also, carts roll with less effort with properly inflated tires. Inflate to 30 p.s.i. approximately every 3 months.

2. Tip: Keep a spare tire just like on your car or bike. Running over a nail or something always happens at the most inconvenient time. Spare wheels are not expensive, install quickly, and can save your gig.

3. Tip: Keep a small 12-Volt air compressor in your car (they plug into a car lighter). Small 12-volt air compressors are inexpensive and extremely handy. People often forget simple tire maintenance until you are on your way to some really important gig.

4. Tip: Keep the nuts on the caster stems firmly tightened.

5. Tip: Purchase an extra caster as a spare in case you damage one. Put a little Loctite or similar thread sealer on caster stem threads to prevent nut from vibrating loose. Casters eventually wear out and it happens at the most inconvenient times.

6. Tip: Remember to retighten the wingbolts after changing the frame length. You only need to loosen the wingbolts ¼ turn to extend or retract the frame.

Troubleshooting

Problem	Cause	Solution
Tire leaking air	Loose Schrader Valve	Typical tires and tubes use a spring-loaded device in the valve stem called a Schrader valve to inflate the tire. The Schrader valve screws into the valve stem and sometimes can become loose causing air leakage. Spray some water on the valve stem. If you see bubbles then its leaking. Take a Schrader valve cap and tighten the valve core.
Tire leaking air	Hole in inner tube	Remove wheel assembly, inflate tire, and place in bucket of water. If you see bubbles then its probably caused by a hole in the tube. Replace entire wheel assembly or Replace/patch tube.
Tire difficult to inflate because valve stem is not centered (sticks out at an angle) or does not stick out far enough from wheel rim.	Sometimes the inner tubes shift position a little inside the wheel rim when the tire is rolled around without being sufficiently inflated.	Remove the wheel, press on the air valve, and deflate the tire about 75%. Note the direction that the tire valve is pointing. Squeeze tire and tube together with one hand and hold the wheel rim with the other hand. Rotate the tire/tube together on the rim until the valve stem is centered and sticks out straight. Inflate the tire to about 30 p.s.i.
Caster stem bent	Nuts loose on threaded stem while carrying loads	Replace caster
Non-skid tape comes off	High humidity. Heavy, sharp-edged equipment.	Get some silicon sealer, smear a line of the sealer on the top of the frame bed tube. Stick the non-skid tape back on and scotch tape it tightly to the frame. Allow to dry for several hours. Remove the scotch tape.



Accessories & More

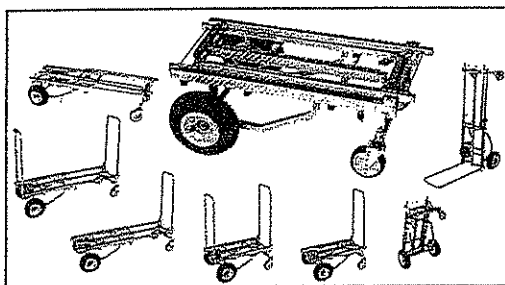

Aluminum Models Now Available

Same dimensions and capacity as corresponding steel models but up to 35% lighter in weight. Tough and stylish extruded aluminum frame. Corrosion resistant.

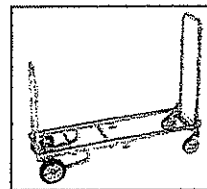
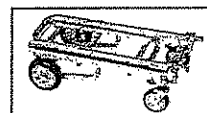

Shelf Kits: Available For All Models

No-Flat Tires: Available For All Models

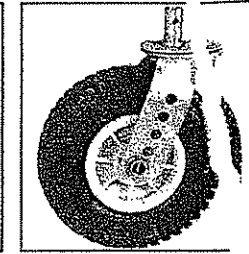
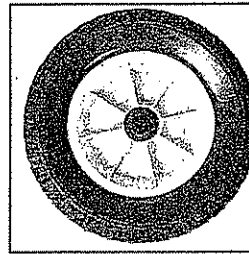
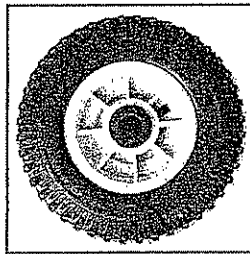
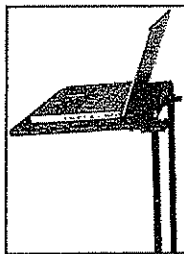
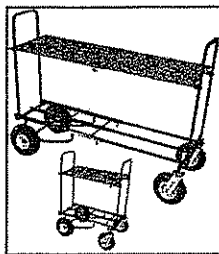
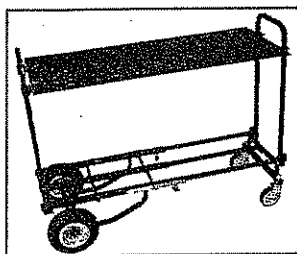

R6 Shelf Kit

R8/R10/R12 Shelf

Mini Shelf

8"x2.50" No-Flat
Offset &
Symmetrical hubs

10"x3.0" No-Flat

8"x2.50" No-Flat
caster assembly

Solid Decks: Available For All Models

Headphone Rack

Piggyback Spool Carrier

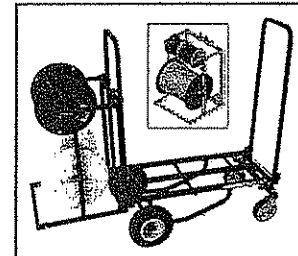
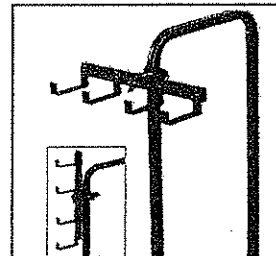
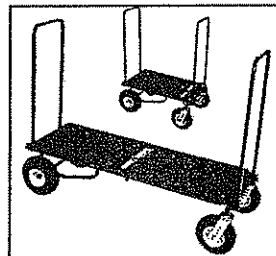
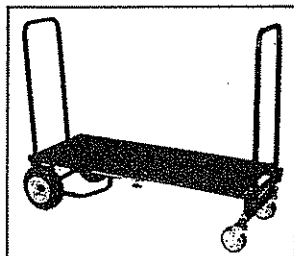
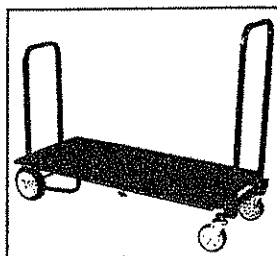

R2 Solid Deck

R6 Solid Deck

R8/R10/R12 Solid Deck

Hang headphones &
cables

Attach to cart or stand
alone

Cases: Fit All Models

Air Compressor

Multi-Clamp

Flex-Straps

Perforated Handles

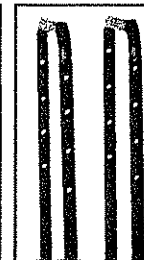
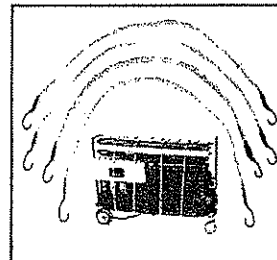
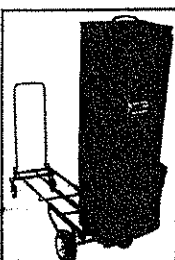

Utility Stand
Case

Transport
Case

6-Pocket
Hangbag

12-Volt Air
Compressor

Universal U-Clamp to
attach accessories to
20mm tube handles.

Strong, flexible tie-
down straps in RnR
colors.

For bolt-on
accessories